



# **NETWORK VIDEO RECORDER SERIES**

## **Quick Installation Guide**

Please read instructions thoroughly before operation and retain it for future reference.

## IMPORTANT SAFEGUARD



All lead-free products offered by the company comply with the requirements of the European law on the Restriction of Hazardous Substances (RoHS) directive, which means our manufacture processes and products are strictly "lead-free" and without the hazardous substances cited in the directive.



The crossed-out wheeled bin mark symbolizes that within the European Union the product must be collected separately at the product end-of-life. This applies to your product and any peripherals marked with this symbol. Do not dispose of these products as unsorted municipal waste. Contact your local dealer for procedures for recycling this equipment.



This is a class A product. In a domestic environment this product may cause radio interference in which case the user may be required to take adequate measures.

### ***Federal Communications Commission Interference Statement***

This equipment has been tested and found to comply with the limits for a Class A digital device, pursuant to Part 15 of the FCC Rules. These limits are designed to provide reasonable protection against harmful interference when the equipment is operated in a commercial environment. This equipment generates, uses, and can radiate radio frequency energy and, if not installed and used in accordance with the instruction manual, may cause harmful interference to radio communications. Operation of this equipment in a residential area is likely to cause harmful interference in which case the user will be required to correct the interference at his own expense.

This device complies with Part 15 of the FCC Rules. Operation is subject to the following two conditions:

- (1) This device must not cause harmful interference, and
- (2) This device must accept any interference received, including interference that may cause undesired operation.

### ***Trademark Acknowledgements***

iPad® & iPhone® are the registered trademarks of Apple Inc.

Android™ is a trademark of Google Inc. Use of this trademark is subject to Google Permissions.

Microsoft®, Windows® & Internet Explorer® are registered trademarks of Microsoft Corporation in the United States and/or other countries.

### ***Disclaimer***

We reserve the right to revise or remove any content in this manual at any time. We do not warrant or assume any legal liability or responsibility for the accuracy, completeness, or usefulness of this manual. The content of this manual is subject to change without notice.

This product doesn't have a standby / shutdown mode.

## ***MPEG4 Licensing***

THIS PRODUCT IS LICENSED UNDER THE MPEG4 VISUAL PATENT PORTFOLIO LICENSE FOR THE PERSONAL AND NON-COMMERCIAL USE OF A CONSUMER FOR (i) ENCODING VIDEO IN COMPLIANCE WITH THE MPEG4 VISUAL STANDARD ("MPEG-4 VIDEO") AND/OR (ii) DECODING MPEG4 VIDEO THAT WAS ENCODED BY A CONSUMER ENGAGED IN A PERSONAL AND NON-COMMERCIAL ACTIVITY AND/OR WAS OBTAINED FROM A VIDEO PROVIDER LICENSED BY MPEG LA TO PROVIDE MPEG4 VIDEO. NO LICENSE IS GRANTED OR SHALL BE IMPLIED FOR ANY OTHER USE. ADDITIONAL INFORMATION INCLUDING THAT RELATING TO PROMOTIONAL INTERNAL AND COMMERCIAL USES AND LICENSING MAY BE OBTAINED FROM MPEG LA, LLC. SEE [HTTP://WWW.MPEGLA.COM](http://www.mpegla.com).

## ***GPL Licensing***



This product contains codes which are developed by Third-Party-Companies and which are subject to the GNU General Public License ("GPL") or the GNU Lesser Public License ("LGPL").

The GPL Code used in this product is released without warranty and is subject to the copyright of the corresponding author.

Further source codes which are subject to the GPL-licenses are available upon request.

We are pleased to provide our modifications to the Linux Kernel, as well as a few new commands, and some tools to get you into the code. The codes are provided on the FTP site, and please download them from the following site or you can refer to your distributor:

# TABLE OF CONTENTS

1. HARDWARE OVERVIEW .....	1
1.1 Front Panel.....	1
1.2 Rear Panel .....	1
2. CONNECTION.....	2
2.1 Simple Connection Diagram.....	2
2.2 Camera IP Configurations by LAN .....	3
2.2.1 Automatically .....	3
2.2.2 Manually .....	3
2.3 Advanced Setup .....	4
3. USER INTERFACE.....	5
3.1 Local.....	5
3.1.1 NVR Status.....	5
3.1.2 Channel Status .....	5
3.1.3 Quick Operation .....	6
3.1.4 Main Menu.....	6
3.1.5 Playback Panel .....	6
3.2 Remote.....	7
4. NETWORK CONFIGURATIONS .....	8
4.1 Understand How Your Laptop / Computer Connect to Internet.....	8
4.2 Router + Modem .....	8
4.3 Modem / Hub + Modem.....	10
APPENDIX 1 MOBILE SURVEILLANCE VIA EAGLEEYES .....	12
A2.1 Prerequisites .....	12
A2.2 Where to download .....	12
APPENDIX 2 COMPATIBLE USB FLASH DRIVE LIST .....	13
APPENDIX 3 COMPATIBLE HARD DISK LIST .....	14
APPENDIX 4 HARD DISK INSTALLATION .....	15
APPENDIX 5 BATTERY REPLACEMENT .....	16

# 1. HARDWARE OVERVIEW

## 1.1 Front Panel

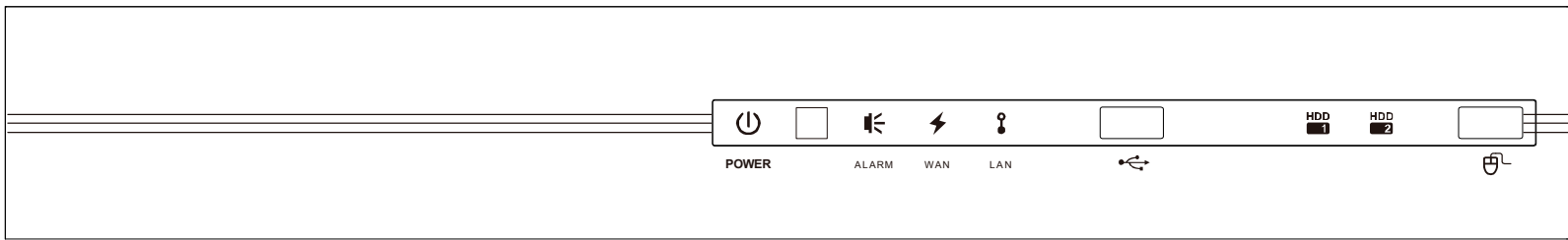

### 1) LED indicators

	The NVR is power-supplied.
	An alarm event occurs.
	The NVR is connected to Internet.
	The NVR is connected to LAN.
HDD	Up to two hard disks are installed in the NVR and connected well.

### 2) USB port (•⇄)

Insert a compatible USB flash drive for video backup.

**Note:** For the compatible list of USB flash drives, please refer to “APPENDIX 2 COMPATIBLE USB FLASH DRIVE LIST” at page 13.

### 3) Mouse port (Ⓜ)

Insert a mouse for function operation.

## 1.2 Rear Panel

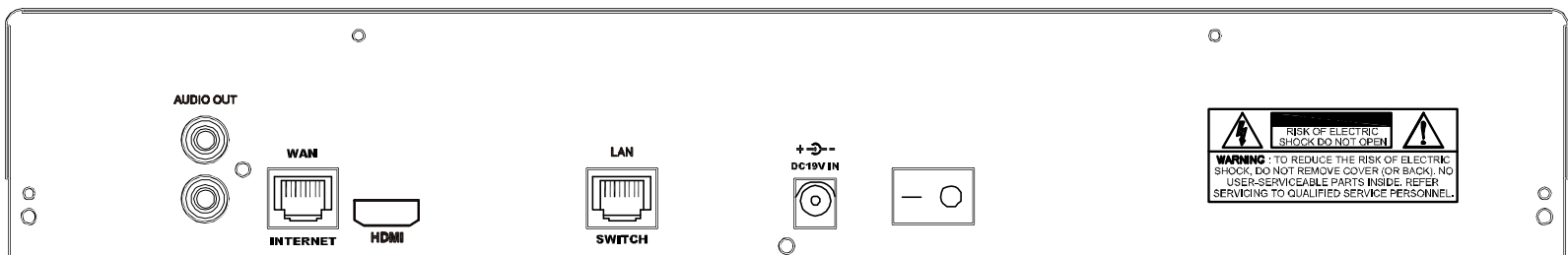

### 1) AUDIO OUT

Connect to a speaker.

### 2) WAN

This port is used to connect your NVR to Internet via a RJ45 network cable.

### 3) HDMI

This port is used to connect the monitor which supports HDMI interface for high definition video output.

**Note:** Direct connection to the monitor which supports VGA or composite interface is not supported. Please prepare a converter in advance.

### 4) LAN

This port is used to connect your NVR to IP cameras locally.

### 5) DC19V IN

Connect the NVR to power with the regulated adapter.

### 6) Power switch (—○)

Switch to “—” to turn on the power, and “○” to turn off the power.

## 2. CONNECTION

### 2.1 Simple Connection Diagram

**Note:** Before connecting the system and powering on the NVR, make sure a hard disk is installed in the NVR for evidentiary recording. To know how to install a hard disk, please refer to "APPENDIX 4 HARD DISK INSTALLATION" at page 15.

Connect up to 6 IP devices:



#### Remote connection\*\*

1. Enter the IP address and access information of the IP camera or DVR in the NVR.
2. Wait till you can see images on the monitor.

#### Local connection\*

1. Connect the camera to a hub.
2. Wait till the camera is configured automatically and you will see camera images on the monitor soon.\*\*\*

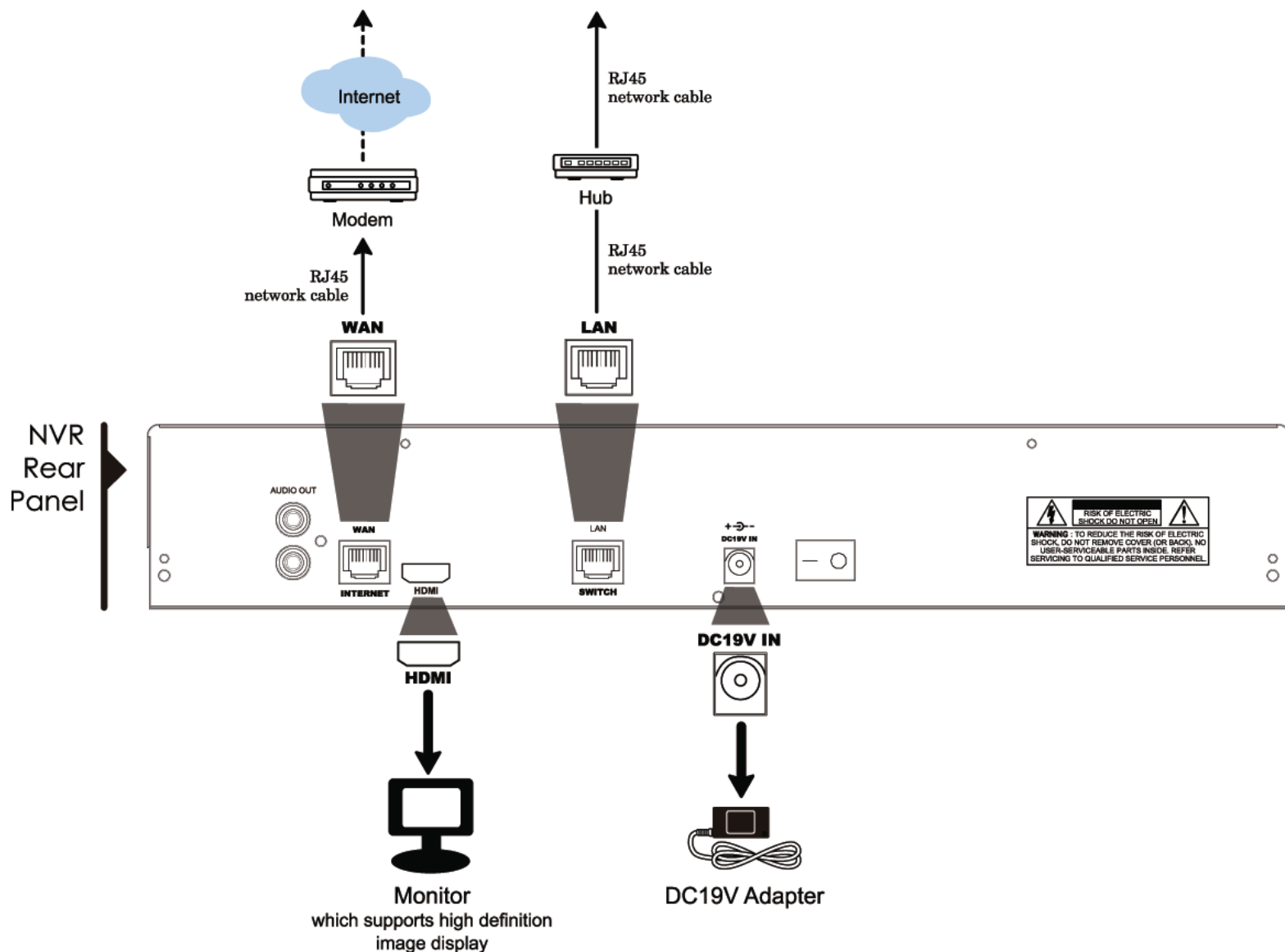

\* Local connection only allows monitoring locally. To monitor from anywhere other than the NVR is installed, please connect your NVR to Internet. For details, please refer to "3. NETWORK CONFIGURATIONS".

\*\* Remote connection is available only when the NVR is connected to Internet. To connect your NVR to Internet, please refer to "3. NETWORK CONFIGURATIONS".

\*\*\* If you don't see camera images, change the IP address of your camera to "10.1.1.xx" (xx ranges from 11 ~ 253). For details, please refer to "2.2 Camera IP Configurations by LAN".

## 2.2 Camera IP Configurations by LAN

### 2.2.1 Automatically

The NVR will automatically configure the IP address of a camera connected by LAN if:

- The connected IP camera is our brand's IP camera.
- The default IP configuration method of the camera is "DHCP".
- The camera is powered on before the NVR is powered on.

If not, you may also configure the IP address of your camera manually as described in "2.3.2 Manually".

### 2.2.2 Manually

If the NVR doesn't configure the IP address of your camera automatically as described above, your IP camera might **NOT** be:

- Our brand's IP camera.
- Set to "DHCP" as its default IP configuration method.

To solve this, use our brand's IP camera, and reconfigure its IP address to 10.1.1.xx (xx ranges from 11 ~ 253), in the same network segment as the NVR.

- a) Select  on the bottom of the screen, You'll see the list of every connected IP camera with its connection status to this NVR and MAC address.
- b) Select the IP address which is not used, and select "SETUP".

IP SEARCH			
IP	PORT	MAC	STATUS
10.1.1.12	88	00:0e:53:e5:9a:f1	BE CONNECTED ON CH1
10.1.1.13	88	00:0e:53:a6:91:18	BE CONNECTED ON CH2
10.1.2.14	88	00:0e:53:a5:9f:a2	UNUSE
10.1.1.15	88	00:0e:53:e1:4e:k5	BE CONNECTED ON CH3
10.1.1.16	88	00:0e:53:s5:3e:h6	BE CONNECTED ON CH4
10.1.1.17	88	00:0e:53:e6:4b:26	BE CONNECTED ON CH5

↕
CONNECT
SETUP
EXIT

- c) Select "STATIC" in "NETWORK TYPE", and change the IP address to 10.1.1.xx (xx ranges from 11 ~ 253)
- d) Click "APPLY" and "EXIT" to save your changes.

SETUP	
NETWORK TYPE	STATIC
IP	10.1.1.14
PORT	88
USER NAME	admin
PASSWORD	*****
NETMASK	255.0.0.0
GATEWAY	10.1.1.10
PRIMARY DNS	168.95.1.1

APPLY
EXIT

- e) The NVR will then detect the IP camera and display images soon.

## 2.3 Advanced Setup

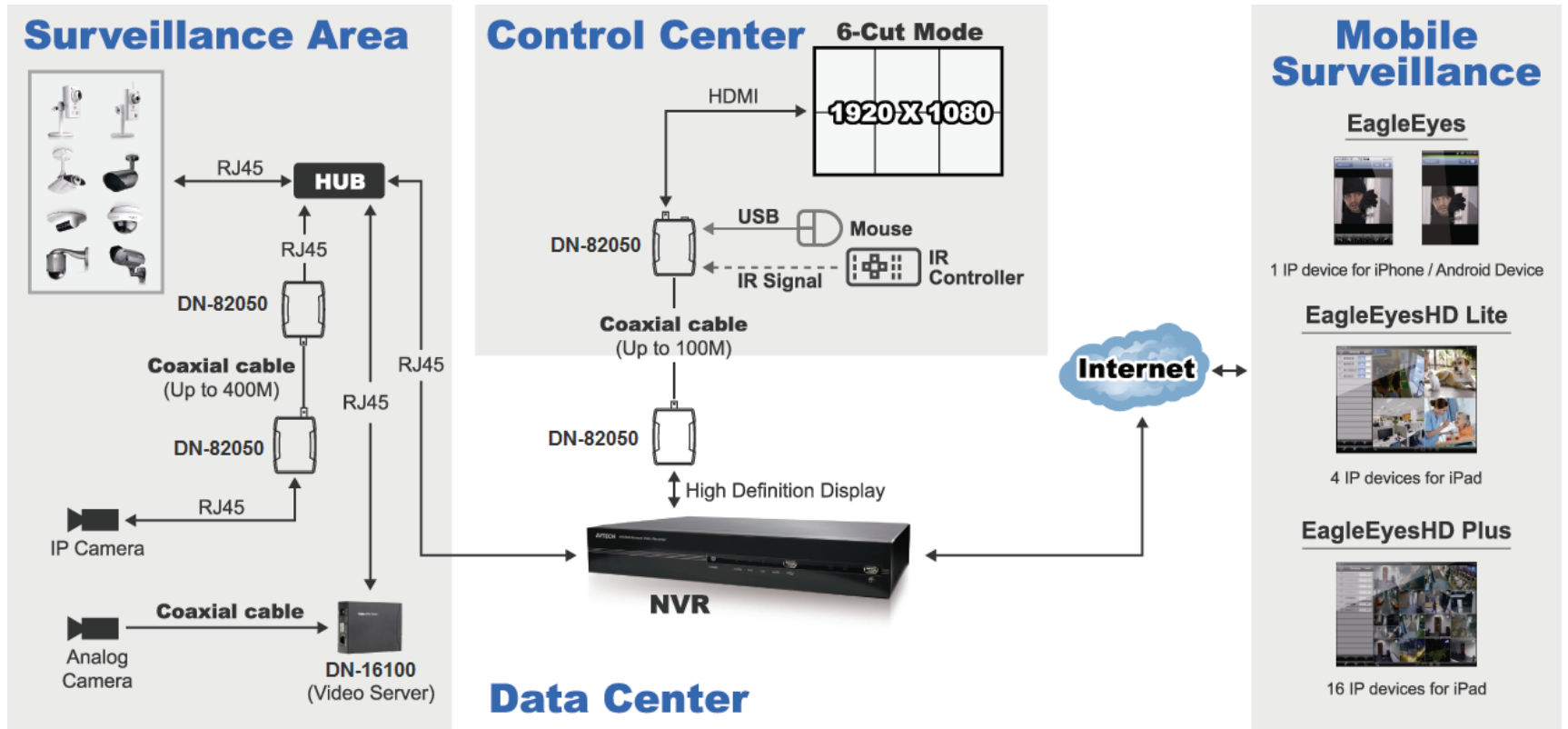

### ▲ Alarm Recording

When an event alarm of an ETS IP camera is triggered by an external alarm-in device or its built-in human detection sensor, the NVR will start HD event recording.

#### ■ Real-time Record Mode (better than 6CH Full D1 device)

CH1	CH2	CH3
1.3M @ 30IPS	1.3M @ 30IPS	1.3M @ 30IPS
CH4	CH5	CH6
VGA @ 30IPS	VGA @ 30IPS	VGA @ 30IPS

#### ■ Smart Event Record Mode (with ETS IP Camera)

**Normal Case** without Event Trigger  
(Record lower resolution or IPS for saving HDD capacity.)

CH1	CH2	CH3
VGA @ 30IPS	VGA @ 30IPS	VGA @ 30IPS
CH4	CH5	CH6
VGA @ 30IPS	VGA @ 30IPS	VGA @ 30IPS

**\*Event Trigger Case** with CH2 / CH4 / CH6 Event Detected  
(CH with ETS IP Camera event trigger will turn to record higher resolution or IPS.)

CH1	CH2	CH3
VGA @ 30IPS	1.3M @ 30IPS	VGA @ 30IPS
CH4	CH5	CH6
1.3M @ 30IPS	VGA @ 30IPS	1.3M @ 30IPS

\*\* Remote connection is available only when the NVR is connected to Internet.

To connect your NVR to Internet, please refer to "3. NETWORK CONFIGURATIONS".

\*\*\* If you don't see camera images, change the IP address of your camera to "10.1.1.xx" (xx ranges from 11 ~ 253).

For details, please refer to "2.2 Camera IP Configurations by LAN".



# 3. USER INTERFACE

## 3.1 Local

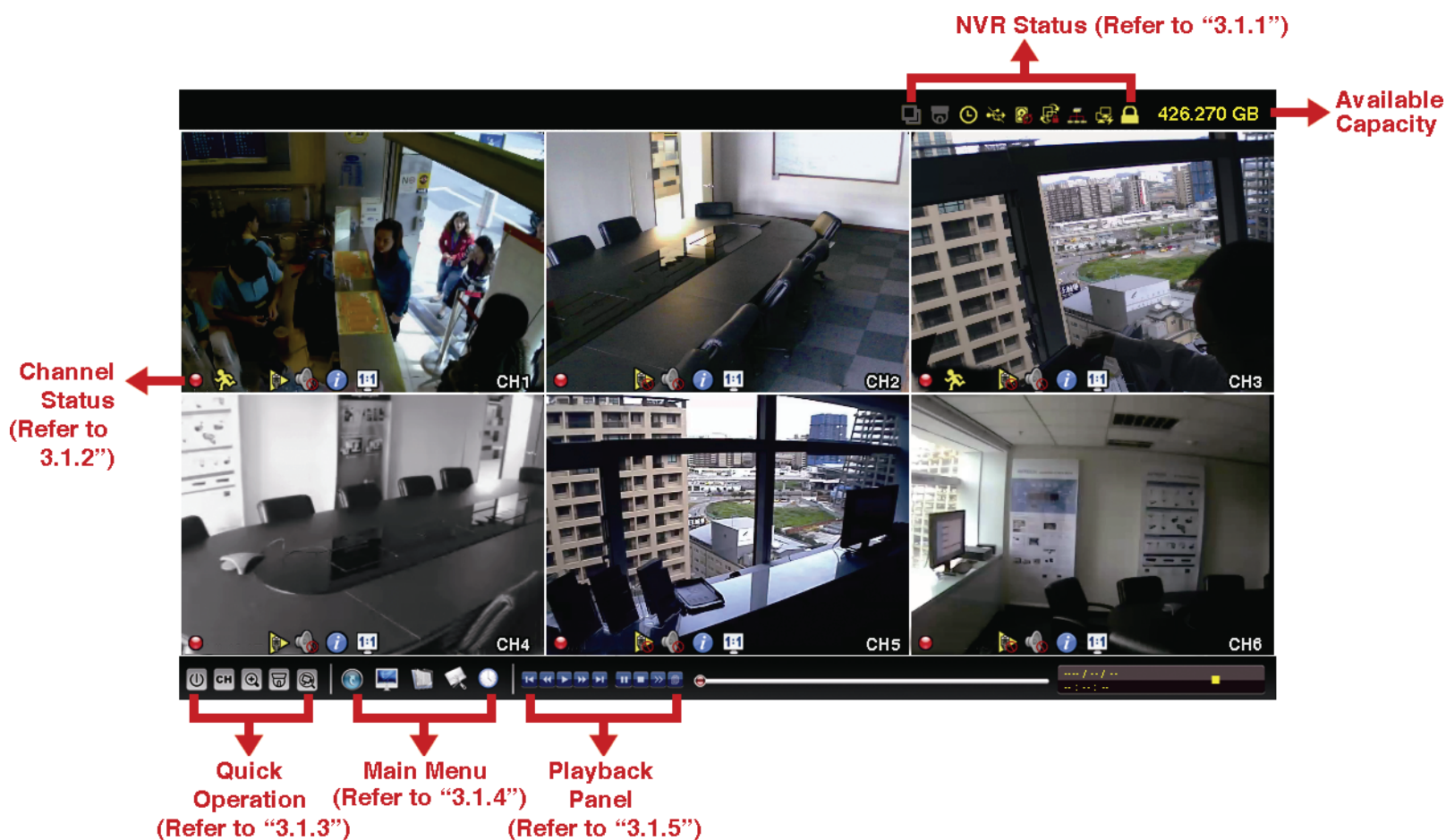

### 3.1.1 NVR Status

	Key lock		Key unlock
	Channel lock		Channel unlock
	USB flash drive / device connected		No USB device connected
	Timer record on		Timer record off
	Overwrite on		Overwrite off
	Sequence mode on		Sequence mode off
	PTZ mode on		PTZ mode off
	CPU loading		







#### Network Status:

	(WAN) Internet connected		(WAN) Internet disconnected
	(WAN) Local connection		
	(LAN) Auto mode -Mbit/s		(LAN) Auto mode -Gbit/s
	(LAN) DHCP / Static IP mode		(LAN) Camera disconnected





### 3.1.2 Channel Status

	Auto search on		Auto search off		Original size		Fit to screen
	Live audio on		Audio off		Audio playback on		Audio playback off
	Recording		Human detection event		Alarm event		Motion event
	Live information		Playback information				









### 3.1.3 Quick Operation

	Click to show the power off panel to either halt or reboot the system.
	Click to show the channel switch panel and select the channel you want.
	Switch to the channel you want first, and click  to enter the zoom-in mode. In this mode, click and drag the red frame on the bottom left of the screen to move to the place you want to see.
	Click to enter the PTZ mode and show the PTZ camera control panel.
	Click to open the IP search window and check the current connection status of each channel.

### 3.1.4 Main Menu

	QUICK START	Click to set the status display, image settings, and date & time.
	SYSTEM	Click to set the system configurations.
	EVENT INFORMATION	Click to enter the event search menu.
	ADVANCED CONFIG	Click to set CONNECTION, CAMERA, DETECTION, ALERT, NETWORK, DISPLAY, RECORD and NOTIFY.
	SCHEDULE SETTING	Click to set record timer.

### 3.1.5 Playback Panel

	Fast Forward	Increase the speed for fast forward.
	Fast Rewind	Increase the speed for fast rewind.
	Play / Pause	Click to play the latest recorded video clip immediately, and click again to pause. In the pause mode, click  once to get one frame forward, and click  to get one frame rewind.
	Stop	Click to stop the video playback.
	Slow Playback	Click once to get 1/4X speed playback, and click twice to get 1/8X speed playback.
	Previous / Next Hour	Click to jump to the next / previous time interval in an hour, for example, 11:00 ~ 12:00 or 14:00 ~ 15:00, and start playing the earliest event video clip recorded during this whole hour.
	Quick Search	Click to enter the quick search menu for specific record data search.

# 3.2 Remote

## Current Streaming Information:

FR: Frame rate  
DR: Data rate  
DATE TIME: Current system time

The screenshot displays a remote monitoring interface with the following components:

- Top Status Bar:** Displays streaming information: "FR: 2.00 fps DR: 1444 kbps DATE TIME: 2011/12/07 07:53:14 MOTION TRIGGER!".
- Channel Status:** A red arrow points to the top-left camera feed, which is labeled "INTERNET".
- Camera Grid:** A 2x3 grid of camera feeds. The top row shows a kitchen area, a meeting room (AVM217), and a window view (AVN257). The bottom row shows another view of the meeting room (AVM317), a different view of the meeting room (AVM328A), and another window view (AVM357A).
- Control Panel:** A bottom toolbar with icons for settings, channel selection (CH), zoom in (+), zoom out (-), full screen, and playback controls (stop, play, previous, next, fast forward, fast reverse). A red arrow points to this panel, which is labeled "Playback Panel".
- Navigation Labels:** Red arrows at the bottom point to "Quick Operation" (under the settings icon), "Main Menu" (under the CH icon), and "Playback Panel" (under the playback icons).

## 4. NETWORK CONFIGURATIONS

**Note:** Network configurations may require a person who has advanced network knowledge. It's recommended to check with your installer for this service if possible.

### 4.1 Understand How Your Laptop / Computer Connect to Internet

#### 1. Router + Modem

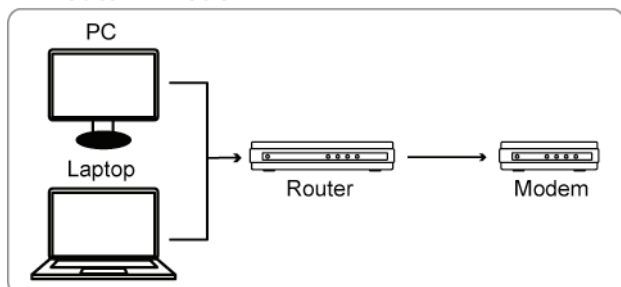

#### 2. Modem or Modem + Hub

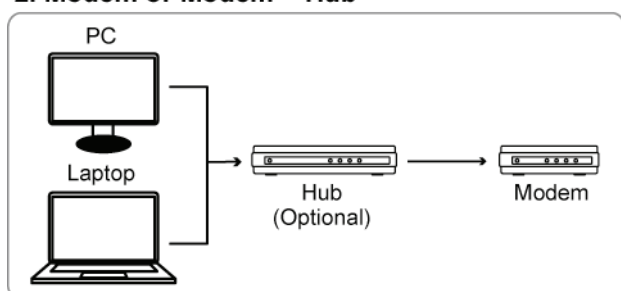

→ Devices connected with a RJ45 network cable

Then, connect your NVR directly to your router / hub / modem with a network cable, and power it on.

If you're using:

- Router + modem, please refer to "4.2 Router + Modem".
- Modem or modem + hub, please refer to "4.3 Modem / Hub + Modem".

### 4.2 Router + Modem

Before configuring, make sure:

- Your laptop / PC is connected to the same router as the NVR is intended to connect to.
- You know the IP address, user name and password to access your router.
- The DHCP function of your router is on.

**Note:** For details, please refer to the user manual of your router.

Step1: Connect your NVR to the router with a RJ45 network cable, similar as follows:

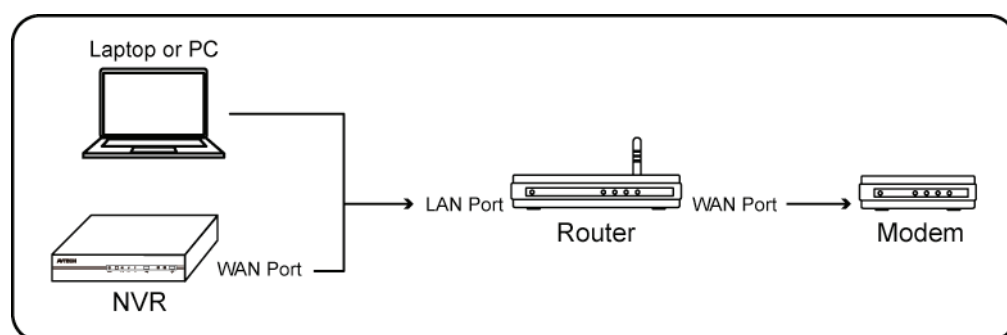

→ Devices connected with a RJ45 network cable

Step2: From your NVR, select  (ADVANCED CONFIG), and select “Network” → “WAN”.

ADVANCED CONFIG	
CONNECTION	WAN   LAN   E-MAIL   DDNS
CAMERA	NETWORK TYPE DHCP
DETECTION	IP 192.168.1.112
ALERT	GATEWAY 192.168.1.254
<b>NETWORK</b>	NETMASK 255.255.255.0
DISPLAY	PRIMARY DNS 168.095.1.1
RECORD	SECONDARY DNS 139.175.55.244
NOTIFY	PORT 88
EXIT	

Step3: Select “DHCP”, and configure the DNS setting and port number.

---

**Note:** DNS is the domain name server obtained from your ISP (Internet Service Provider).

---

**Note:** The default port number is 80. Typically, the TCP port used by HTTP is 80. However in some cases, it is better to change this port number for added flexibility or security.

---

Then, note down the IP address shown in “IP”. This is the IP address assigned to your NVR by the router. You’ll need it later for port forwarding.

Step4: Go to “DDNS”, and select “eagleeyes” in “SYSTEM NAME”.

Note down the whole address under “CURRENT HOST ADDRESS”, such as MAC000E5318B3F0@ddns.dvrtw.com.tw. This will be the address used to access your NVR remotely.

ADVANCED CONFIG	
CONNECTION	WAN   LAN   E-MAIL   DDNS
CAMERA	DDNS ON
DETECTION	SYSTEM NAME eagleeyes
ALERT	HOST NAME MAC000E5318B3F0
<b>NETWORK</b>	E-MAIL EMPTY
DISPLAY	
RECORD	
NOTIFY	
EXIT	CURRENT HOST ADDRESS MAC000E5318B3F0.ddns.dvrtw.com.tw

Then, select “EXIT” to return to the live view, and continue to Step5 for port forwarding.

Step5: From the web browser of your PC, enter the IP address of your router to access your router.

---

**Note:** Enter the user name and password if needed.

---

Step6: In the router setting interface, go to the port forwarding (or virtual server) rule configuration page.

---

**Note:** The naming of port forwarding or virtual server may vary based on different router brands. To know where it is, please refer to the user manual of your router.

---

Then, enter the NVR IP address and the port number you note down in Step3, and enable this rule.

IP Address:	The IP address of the NVR, such as 192.168.1.112 in our example.
Ports to Open:	The port number you set for the NVR, such as 88 in our example.

### **Check your connection**

Step1: Open your web browser, e.g. Internet Explorer.

Step2: Enter the NVR address and the port number in the URL address box of the web browser, and see if you can access the login page of the camera successfully.

The format is “**http://ipaddress:portnum**” or “**http://hostaddress:portnum**”.

### 4.3 Modem / Hub + Modem

Before configuring, make sure:

- You know you're using static IP address or PPPoE for Internet service.
- For users with static IP address, make sure you get the information of the static IP address, gateway and net mask from your ISP (Internet Service Provider).
- For users with PPPoE, make sure you get the user name and password from your ISP (Internet Service Provider).

Step1: Connect your NVR to the hub or modem with a RJ45 network cable, similar as follows:

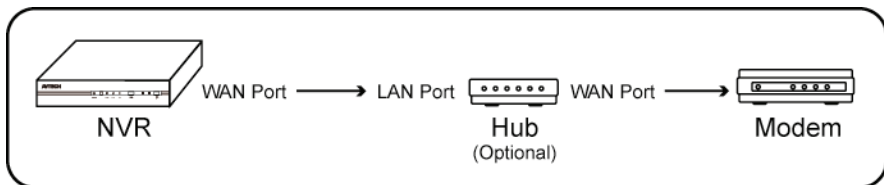

→ Devices connected with a RJ45 network cable

Step2: From your NVR, select  (ADVANCED CONFIG), and select “Network” → “WAN”.

ADVANCED CONFIG				
	WAN	LAN	E-MAIL	DDNS
CONNECTION	NETWORK TYPE		PPPOE	
CAMERA	IP		192.168.1.112	
DETECTION	GATEWAY		192.168.1.254	
ALERT	NETMASK		255.255.255.0	
<b>NETWORK</b>	PRIMARY DNS		168.095.1.1	
DISPLAY	SECONDARY DNS		139.175.055.244	
RECORD	PORT		88	
NOTIFY	USER NAME		head-office	
	PASSWORD		*****	
EXIT				

Step3: Select “STATIC”, “PPPOE” or “**DHCP**” based on your network type, and change the port number if needed.

- For “**STATIC**”, enter the information of the static IP address, gateway and net mask from your ISP.
- For “**PPPOE**”, enter the user name and password from your ISP.
- For “**DHCP**”, go to “Step4” directly for port forwarding.

**Note:** The default port number is 80. Typically, the TCP port used by HTTP is 80. However in some cases, it is better to change this port number for added flexibility or security.

Step4: (PPPOE & DHCP Only) Go to “DDNS”, and select “eagleeyes” in “SYSTEM NAME”.

Note down the whole address under “CURRENT HOST ADDRESS”, such as MAC000E5318B3F0@ddns.dvrtw.com.tw. This will be the address used to access your NVR remotely.

ADVANCED CONFIG				
	WAN	LAN	E-MAIL	DDNS
CONNECTION	DDNS		ON	
CAMERA	SYSTEM NAME		eagleeyes	
DETECTION	HOST NAME		MAC000E5318B3F0	
ALERT	E-MAIL		EMPTY	
<b>NETWORK</b>				
DISPLAY	CURRENT HOST ADDRESS			
RECORD	MAC000E5318B3F0.ddns.dvrtw.com.tw			
NOTIFY				
EXIT				

Then, select “EXIT” to return to the live view and finish network configurations.

**Check your connection**

Step1: Open your web browser, e.g. Internet Explorer.

Step2: Enter the IP address (STATIC) or host address (PPPOE / DHCP), and the port number in the URL address box of the web browser, and see if you can access the login page of the camera successfully.

The format is "***http://ipaddress:portnum***" or "***http://hostaddress:portnum***".

## APPENDIX 1 MOBILE SURVEILLANCE VIA EAGLEEYES

*EagleEyes* is a mobile phone program used with our surveillance system for remote surveillance. It has several advantages:

- It's free (Except *EagleEyes Plus* for iPhone).
- It's compatible with several popular mobile platforms, such as iPhone, iPad and Android.

It's easy to download, install and configure. For more details about configuring and operating this program, please visit our official website [www.eagleeyesccv.com](http://www.eagleeyesccv.com).

### A2.1 Prerequisites

Before installing *EagleEyes* to your mobile phone for remote surveillance, make sure you have checked the following:

- ✓ Your mobile platform is iPhone, iPad & Android.
- ✓ Mobile Internet services are subscribed and available to use for your mobile phone.

---

**Note:** You might be charged for Internet access via wireless or 3G networks. For the Internet access rate details, please check with your local network operator or service provider.

- ✓ You have noted down the IP address, port number, user name and password used to access your network camera from Internet.

### A2.2 Where to download

Connect to [www.eagleeyesccv.com](http://www.eagleeyesccv.com) from your mobile phone, and sign in.

---

**Note:** Please **DO NOT** try to download *EagleEyes* from your computer.

Then, select "Software" and the mobile platform of your phone to download *EagleEyes* to your phone.

- For Android & iPad, select the download link from the website to start downloading.
- For iPhone, two versions of *EagleEyes* are available:
  - *EagleEyes Plus* (US\$4.99), and
  - *EagleEyes Lite* (Free).

Select the version you want, and you'll be directed to "App Store" to download the application.

---

**Note:** You can also find *EagleEyes* on "App Store" from your iPhone. Go to "App Store", and select "Search". Enter the keyword "eagleeyes" to find and download the version you want.

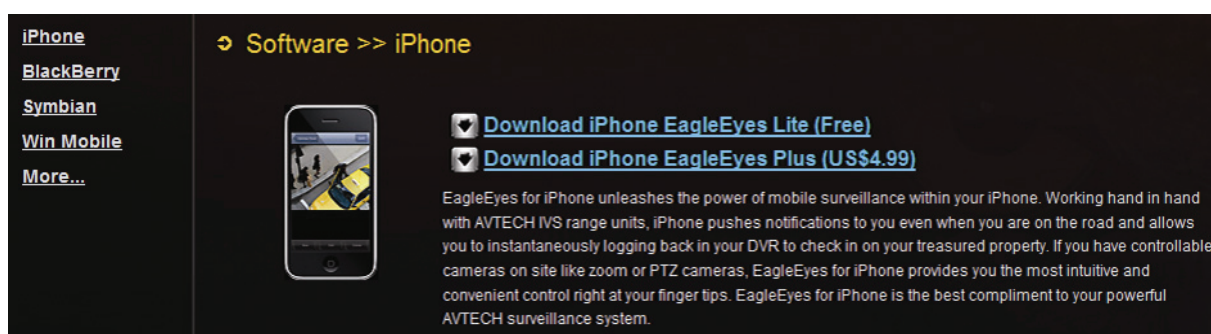

When the download is completed, *EagleEyes* will be installed automatically to the location where all applications are saved in your phone by default, or where you specify.

---

**Note:** For more details about configuring and operating this program, please visit our official website [www.eagleeyesccv.com](http://www.eagleeyesccv.com).



## APPENDIX 2 COMPATIBLE USB FLASH DRIVE LIST

Please upgrade the firmware of the NVR to the latest version to ensure the accuracy of the following table. If the USB flash drive is not supported by the NVR, the “USB ERROR” message will be shown on the screen.

**Note:** Please use your PC to format the USB flash drive as “FAT32”.

**Note:** You can backup up to 2GB video data for one-time USB backup. To backup more data, please set the time & channel(s) you want, and start USB backup again.

MANUFACTURER	MODEL	CAPACITY
Transcend	JFV35	4G
	JFV30	8G
Kingston	DataTraveler	1G
PQI	U172P	4G
Apacer	AH320	2GB
	AH320A	8GB
	AH220	1GB
	AH320	4GB
A-data	RB-18	1GB
Sandisk	Cruzer Micro	2G
	Cruzer Micro	4G
	Cruzer4-pk	2G
Netac	U208	1G
MSI	F200	4G
SONY	Micro Vault Tiny 2G	2G
	Micro Vault Tiny 4G	4G
	Micro Vault Tiny	1G

## APPENDIX 3 COMPATIBLE HARD DISK LIST

Please upgrade the firmware of the device to the latest version to ensure the accuracy of the following table.

MANUFACTURER	MODEL	CAPACITY	ROTATION
Seagate	ST3320613AS	320GB	7200 rpm
	ST33500320AS	500GB	7200 rpm
	ST3500410SV	500GB	7200 rpm
	ST3750330AS	750GB	7200 rpm
	ST31000525SV	1000GB	7200 rpm
	ST31000340AS	1000GB	7200 rpm
WD	WD3200AAKS	320GB	7200 rpm
	WD5000AACS	500GB	7200 rpm
	WD6400AAKS	640GB	7200 rpm
	WD7500AAKS	750GB	7200 rpm
	WD10EADS	1TB	7200 rpm
	WD15EADS	1.5TB	7200 rpm
	WD20EADS	2TB	7200 rpm
Maxtor	STM3500320AS	500GB	7200 rpm
	STM3750330AS	750GB	7200 rpm
HITACHI	HDT725032VLA360	320GB	7200 rpm
	HDS721010KLA330	1000GB	7200 rpm

## APPENDIX 4 HARD DISK INSTALLATION

Step1: Remove the top cover.

Step2: Find the hard disk bracket in the DVR, and place the compatible hard disk in the bracket.

Step3: With the PCB side facing up, connect the hard disk to the power connector and data connector.

Step4: Fasten the hard disk with the supplied screws, two for each side.

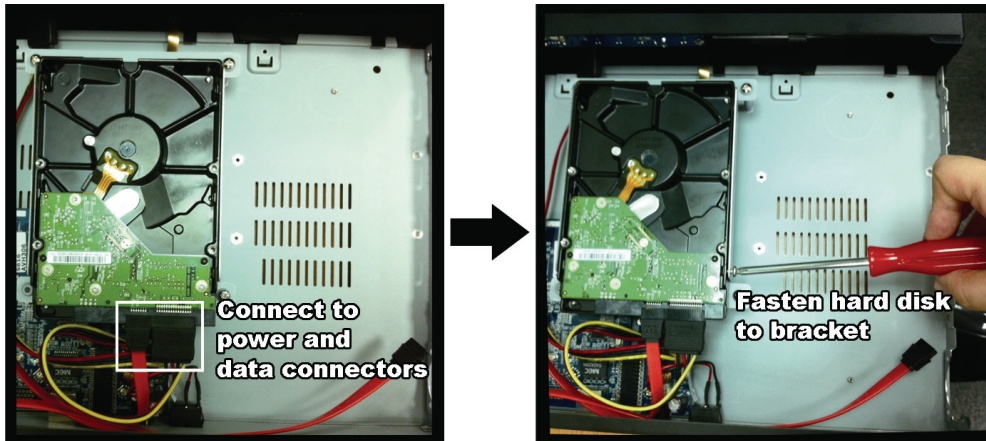

Step5: To install another hard disk, find the supplied hard disk brackets in the package, and fix them onto the NVR base.

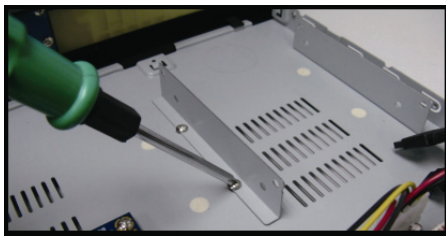

Step6: With the PCB side facing up, connect the hard disk to the power connector and data connector.

Step7: Then, put the hard disk in the bracket, and fasten it with the supplied screws, two for each side.

Step8: Replace the top cover and fasten the screws you loosened in Step1.

## APPENDIX 5 BATTERY REPLACEMENT

The time reset after power failure, for example, caused by a power outage, will cause the disorder of the recorded data, and users may have problems in searching the event clip they want. To keep the device time from resetting, a non-chargeable lithium battery, CR2032, is installed in the device.

However, the device time might still get reset when the battery is low or even running out of power. If so, please replace the device battery, CR2032, **right away** as instructed below.

### ➤ How to replace CR2032

---

**Note:** The lithium battery, CR2032, is a non-chargeable battery, and should be purchased separately. Please replace only with the same or equivalent type battery in case of danger.

---

Step1: Stop all recording **immediately** to prevent the disorder of the recorded data. Then, back up the recorded data if necessary.

Step2: Power off the device, and disconnect the power.

Step3: Remove the device cover, and find the battery on the mainboard.

Step4: Push the release as indicated below to remove the battery.

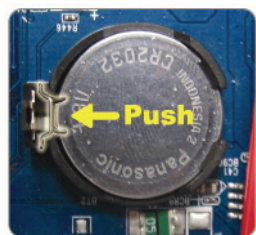

**Type1**

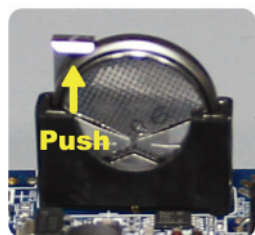

**Type 2**

Step5: Get a new battery and install it to its slot on the mainboard.

- For Type 1, install it with the side of "CR2032" facing up as shown above.
- For Type 2, install it without the side of "CR2032" facing you as shown above.

Step6: Replace the cover and connect to power.

Step7: Set the date & time, and resume recording.